

Memory FeRAM

4 M (512 K × 8) Bit

MS85R4M1TA

■ DESCRIPTIONS

The MS85R4M1TA is an FeRAM (Ferroelectric Random Access Memory) chip consisting of 524,288 words × 8 bits of nonvolatile memory cells fabricated using ferroelectric process and silicon gate CMOS process technologies.

The MS85R4M1TA is able to retain data without using a back-up battery, as is needed for SRAM.

The memory cells used in the MS85R4M1TA can be used for 10^{14} read/write operations, which is a significant improvement over the number of read and write operations supported by Flash memory and E2PROM. The MS85R4M1TA uses a pseudo-SRAM interface.

■ FEATURES

- Bit configuration : 524,288 words × 8 bits
- Read/write endurance : 10^{14} times (+ 85 °C), 10^{13} times (+ 105 °C),
- Data retention : 10 years (+ 105 °C), 40 years (+ 85 °C), over 200 years (+ 35 °C)
- Operating power supply voltage : 1.8 V to 3.6 V
- Low power operation : Operating power supply current 16 mA (Max)
Standby current 150 μA (Max)
Sleep current 12 μA (Max)
- Operation ambient temperature range : - 40 °C to + 105 °C
- Package : 44-pin plastic TSOP
RoHS compliant

Fujitsu Semiconductor Memory Solutions Limited has changed its name to RAMXEED Limited.
RAMXEED Limited will continue to offer and support existing products while maintaining Fujitsu's part number unchanged.

MS85R4M1TA

■ PIN ASSIGNMENTS

PIN ASSIGNMENTS(Continued)

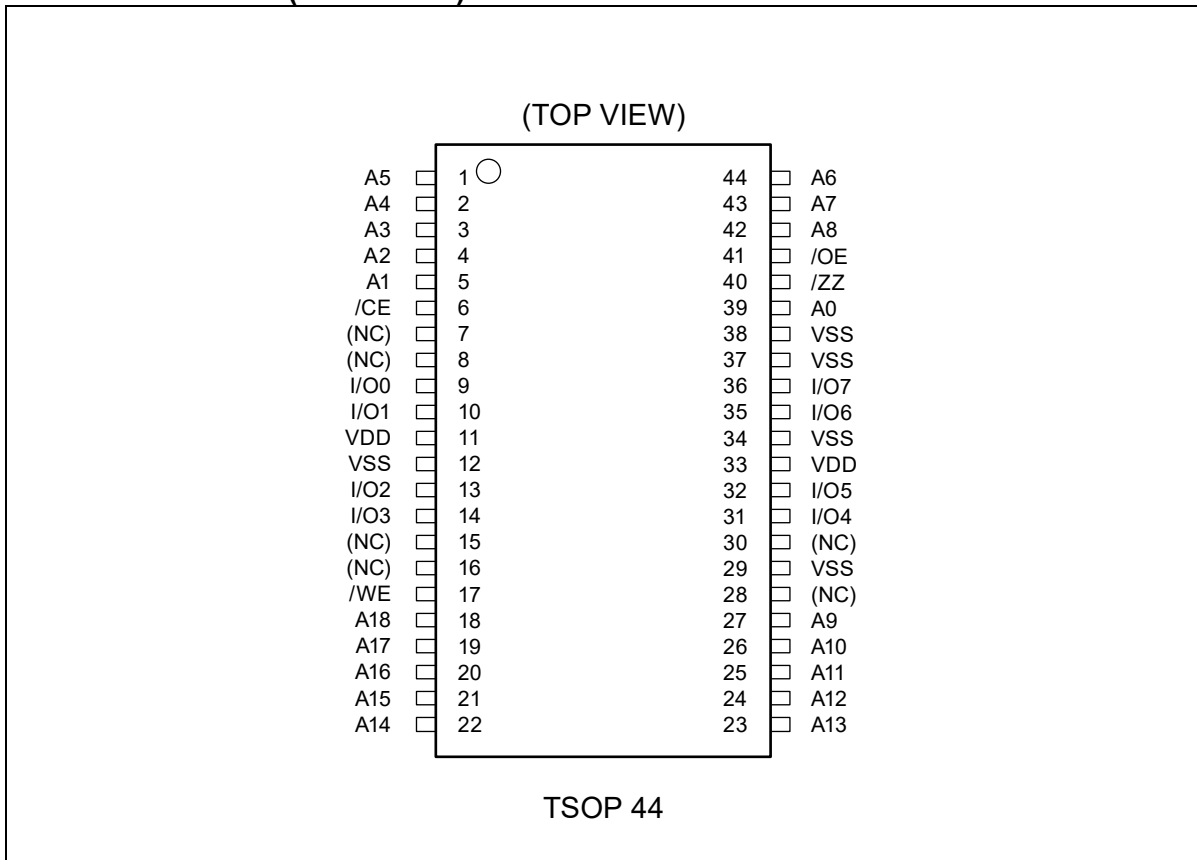

MS85R4M1TA

■ PIN DESCRIPTIONS

Pin Number(TSOP)	Pin Name	Functional Description
39, 5 to 1, 44 to 42, 27 to 18	A0 to A18	Address Input pins Select 262,144 words in FeRAM memory array by 18 Address Input pins. When these address inputs are changed during /CE equals to “L” level, reading operation of data selected in the address after transition will start.
9 to 10, 13 to 14, 31 to 32, 35 to 36	I/O0 to I/O7	Data Input/Output pins These are 8 bits bidirectional pins for reading and writing.
6	/CE	Chip Enable Input pin In case the /CE equals to “L” level and /ZZ equals to “H” level, device is activated and enables to start memory access. In writing operation, input data from I/O pins are latched at the rising edge of /CE and written to FeRAM memory array.
17	/WE	Write Enable Input pin Writing operation starts at the falling edge of /WE. Input data from I/O pins are latched at the rising edge of /WE and written to FeRAM memory array.
41	/OE	Output Enable Input pin When the /OE is “L” level, valid data are output to data bus. When the /OE is “H” level, all I/O pins become high impedance (High-Z) state.
40	/ZZ	Sleep Mode Input pin When the /ZZ becomes to “L” level, device transits to the Sleep Mode. During reading and writing operation, /ZZ pin shall be hold “H” level.
11, 33	VDD	Supply Voltage pins Connect all two pins to the power supply.
12, 29, 34, 37, 38	VSS	Ground pins Connect all pins to ground.
7 to 8, 15 to 16, 28, 30	NC	No connected pins Leave them open or connect to VDD or VSS.

Note: Please refer to the timing diagram for functional description of each pin.

MS85R4M1TA

■ BLOCK DIAGRAM

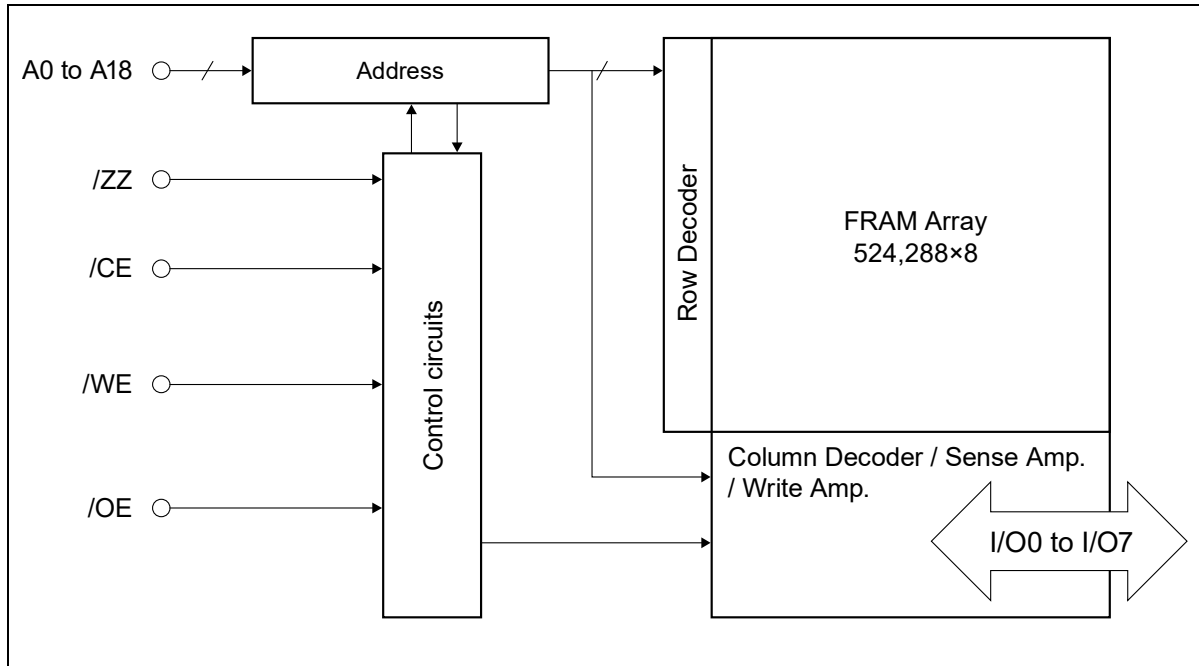

■ FUNCTIONAL TRUTH TABLE

Operation Mode	/CE	/WE	/OE	A0 to A2	A3 to A18	/ZZ
Sleep	×	×	×	×	×	L
Standby	H	×	×	×	×	H
Read(/CE Control)	↓	H	L	H or L	H or L	H
Address Access Read	L	H	L	H or L	↑ or ↓	H
Write(/CE Control) ^{*1}	↓	L	×	H or L	H or L	H
Write(/WE Control) ^{*1*2}	L	↓	×	H or L	H or L	H
Address Access Write ^{*1*3}	L	↓	×	H or L	↑ or ↓	H
Pre-charge	↑	×	×	×	×	H
Page Read	L	H	L	↑ or ↓	H or L	H
Page Address Write	L	↓	H	↑ or ↓	H or L	H

Note: H= "H" level, L= "L" level, ↑= Rising edge, ↓= Falling edge, ×= H, L, ↓ or ↑

*1: In writing cycle, input data is latched at early rising edge of /CE or /WE.

*2: In writing sequence of /WE control, there exists time with data output of reading cycle at the falling edge of /CE.

*3: In writing sequence of Address Access Write, there exists time with data output of reading cycle at the address transition.

MS85R4M1TA

State Transition Diagram

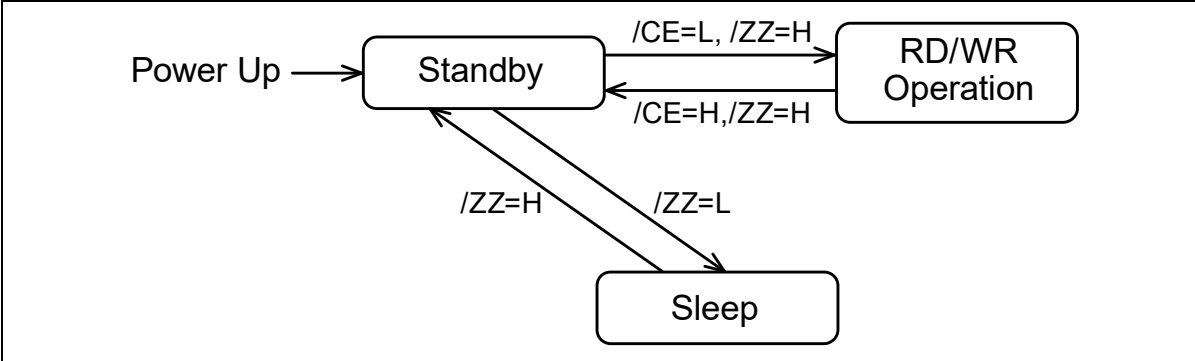

MS85R4M1TA

■ ABSOLUTE MAXIMUM RATINGS

Parameter	Symbol	Rating		Unit
		Min	Max	
Power Supply Voltage*	V _{DD}	- 0.5	+ 4.0	V
Input Pin Voltage*	V _{IN}	- 0.5	V _{DD} + 0.5 (≤ 4.0)	V
Output Pin Voltage*	V _{OUT}	- 0.5	V _{DD} + 0.5 (≤ 4.0)	V
Operation Ambient Temperature	T _A	- 40	+ 105	°C
Storage Temperature	T _{stg}	- 55	+ 125	°C

* : All voltages are referenced to VSS (ground 0 V).

WARNING: Semiconductor devices can be permanently damaged by application of stress (voltage, current, temperature, etc.) in excess of absolute maximum ratings. Do not exceed these ratings.

■ RECOMMENDED OPERATING CONDITIONS

Parameter	Symbol	Value			Unit
		Min	Typ	Max	
Power Supply Voltage* ¹	V _{DD}	1.8	3.3	3.6	V
Operation Ambient Temperature* ²	T _A	- 40	—	+ 105	°C

*1: All voltages are referenced to VSS (ground 0 V).

*2: Ambient temperature when only this device is working. Please consider it to be the almost same as the package surface temperature.

WARNING: The recommended operating conditions are required in order to ensure the normal operation of the semiconductor device. All of the device's electrical characteristics are warranted when the device is operated within these ranges.

Always use semiconductor devices within their recommended operating condition ranges. Operation outside these ranges may adversely affect reliability and could result in device failure.

No warranty is made with respect to uses, operating conditions, or combinations not represented on the data sheet. Users considering application outside the listed conditions are advised to contact their representatives beforehand.

MS85R4M1TA

■ ELECTRICAL CHARACTERISTICS

1. DC Characteristics

(within recommended operating conditions)

Parameter	Sym-bol	Condition	Value				Unit
			Min	Typ	Max(TA ≤85°C)	Max(TA ≥ 85°C)	
Input Leakage Current	I _{LI}	V _{IN} = 0V to V _{DD}	—	—	5		μA
Output Leakage Current	I _{LO}	V _{OUT} = 0V to V _{DD} /CE = V _{IH} or /OE = V _{IH}	—	—	5		μA
Operating Power Supply Current*1	I _{DD}	/CE = 0.2 V, I _{out} = 0 mA	—	13.5	16	16	mA
Standby Current	I _{SB}	/ZZ ≥ V _{DD} - 0.2V /CE, /WE, /OE ≥ V _{DD} - 0.2V Others ≥ V _{DD} - 0.2V or ≤ 0.2V	—	12	100	150	μA
Sleep Current	I _{ZZ}	/ZZ = V _{SS} /CE, /WE, /OE ≥ V _{DD} - 0.2V Others ≥ V _{DD} - 0.2V or ≤ 0.2V	—	3.5	10	12	μA
High Level Input Voltage	V _{IH}	V _{DD} = 1.8V to 3.6V	V _{DD} × 0.8	—	V _{DD} + 0.3		V
Low Level Input Voltage	V _{IL}	V _{DD} = 1.8V to 3.6V	- 0.3	—	V _{DD} × 0.2		V
High Level Output Voltage	V _{OH1}	V _{DD} = 2.5V to 3.6V I _{OH} = - 1.0mA	V _{DD} × 0.8	—	—		V
	V _{OH2}	V _{DD} = 1.8V to 2.5V I _{OH} = - 100μA	V _{DD} - 0.2	—	—		
Low Level Output Voltage	V _{OL1}	V _{DD} = 2.5V to 3.6V I _{OL} = 2.0mA	—	—	0.4		V
	V _{OL2}	V _{DD} = 1.8V to 2.5V I _{OL} = 150μA	—	—	0.2		

*1: During the measurement of I_{DD}, all Address and I/O were taken to only change once per active cycle.
I_{out} : output current

MS85R4M1TA

2. AC Characteristics

• AC Test Conditions

Power Supply Voltage	: 1.8 V to 3.6 V
Operation Ambient Temperature	: -40 °C to +105 °C
Input Voltage Amplitude	: 0 V / V _{DD}
Input Rising Time	: 3 ns
Input Falling Time	: 3 ns
Input Evaluation Level	: V _{DD} /2
Output Evaluation Level	: V _{DD} /2
Output Load Capacitance	: 30 pF

(1) Read Cycle

Parameter	Symbol	TA ≤ +85°C				Unit
		Value (V _{DD} =1.8V to 2.5V)		Value (V _{DD} =2.5V to 3.6V)		
		Min	Max	Min	Max	
Read Cycle time(/CE control)	t _{RC}	120	—	120	—	ns
Read Cycle time(Address access)	t _{RCA}	135	—	120	—	ns
/CE Access Time	t _{CE}	—	65	—	65	ns
Address Access Time	t _{AA}	—	135	—	120	ns
/CE Output Data Hold time	t _{OH}	0	—	0	—	ns
Address Access Output Data Hold time	t _{OA}	20	—	20	—	ns
/CE Active Time	t _{CA}	65	—	65	—	ns
Pre-charge Time	t _{PC}	55	—	55	—	ns
Address Setup Time	t _{AS}	0	—	0	—	ns
Address Hold Time	t _{AH}	65	—	65	—	ns
/CE↑ to Address Transition time*1	t _{CAH}	0	—	0	—	ns
/OE Access Time	t _{OE}	—	35	—	20	ns
/CE Output Floating Time*1	t _{HZ}	—	10	—	10	ns
/OE Output Floating Time	t _{OHZ}	—	10	—	10	ns
Address Transition Time*1	t _{AX}	—	15	—	15	ns

*1: Same parameters with the Write cycle.

MS85R4M1TA

Parameter	Symbol	TA≥+85°C				Unit
		Value (V _{DD} =1.8V to 2.5V)		Value (V _{DD} =2.5V to 3.6V)		
		Min	Max	Min	Max	
Read Cycle time(/CE control)	t _{RC}	125	—	125	—	ns
Read Cycle time(Address access)	t _{RCA}	140	—	125	—	ns
/CE Access Time	t _{CE}	—	70	—	70	ns
Address Access Time	t _{AA}	—	140	—	125	ns
/CE Output Data Hold time	t _{OH}	0	—	0	—	ns
Address Access Output Data Hold time	t _{OAH}	20	—	20	—	ns
/CE Active Time	t _{CA}	70	—	70	—	ns
Pre-charge Time	t _{PC}	55	—	55	—	ns
Address Setup Time	t _{AS}	0	—	0	—	ns
Address Hold Time	t _{AH}	70	—	70	—	ns
/CE↑ to Address Transition time* ¹	t _{CAH}	0	—	0	—	ns
/OE Access Time	t _{OE}	—	35	—	20	ns
/CE Output Floating Time* ¹	t _{HZ}	—	10	—	10	ns
/OE Output Floating Time	t _{OHZ}	—	10	—	10	ns
Address Transition Time* ¹	t _{AX}	—	15	—	15	ns

*1: Same parameters with the Write cycle.

(2) Write Cycle

Parameter	Symbol	TA≤+85°C				Unit
		Value (V _{DD} =1.8V to 2.5V)		Value (V _{DD} =2.5V to 3.6V)		
		Min	Max	Min	Max	
Write Cycle Time	t _{WC}	120	—	120	—	ns
/CE Active Time	t _{CA}	65	—	65	—	ns
/CE↓ to /WE↑ Time	t _{CW}	65	—	65	—	ns
Pre-charge Time	t _{PC}	55	—	55	—	ns
Write Pulse Width	t _{WP}	20	—	20	—	ns
Address Setup Time	t _{AS}	0	—	0	—	ns
Address Hold Time	t _{AH}	65	—	65	—	ns
/WE↓ to /CE↑ Time	t _{WLC}	20	—	20	—	ns
Address Transition to /WE↑ Time	t _{AWH}	135	—	120	—	ns
/WE↑ to Address Transition Time	t _{WHA}	0	—	0	—	ns
Data Setup Time	t _{DS}	10	—	10	—	ns
Data Hold Time	t _{DH}	0	—	0	—	ns
/WE Output Floating Time	t _{WZ}	—	10	—	10	ns
/WE Output Access Time* ¹	t _{WX}	10	—	10	—	ns
Write Setup Time* ¹	t _{WS}	0	—	0	—	ns
Write Hold Time* ¹	t _{WH}	0	—	0	—	ns
/CE Output Floating Time	t _{HZ}	—	10	—	10	ns
Address transition Time	t _{AX}	—	15	—	15	ns

MS85R4M1TA

Parameter	Symbol	TA≥+85°C				Unit
		Value (V _{DD} =1.8V to 2.5V)		Value (V _{DD} =2.5V to 3.6V)		
		Min	Max	Min	Max	
Write Cycle Time	t _{WC}	125	—	125	—	ns
/CE Active Time	t _{CA}	70	—	70	—	ns
/CE↓ to /WE↑ Time	t _{CW}	70	—	70	—	ns
Pre-charge Time	t _{PC}	55	—	55	—	ns
Write Pulse Width	t _{WP}	20	—	20	—	ns
Address Setup Time	t _{AS}	0	—	0	—	ns
Address Hold Time	t _{AH}	70	—	70	—	ns
/WE↓ to /CE↑ Time	t _{WLC}	20	—	20	—	ns
Address Transition to /WE↑ Time	t _{AWH}	140	—	125	—	ns
/WE↑ to Address Transition Time	t _{WHA}	0	—	0	—	ns
Data Setup Time	t _{DS}	10	—	10	—	ns
Data Hold Time	t _{DH}	0	—	0	—	ns
/WE Output Floating Time	t _{WZ}	—	10	—	10	ns
/WE Output Access Time*1	t _{WX}	10	—	10	—	ns
Write Setup Time*1	t _{WS}	0	—	0	—	ns
Write Hold Time*1	t _{WH}	0	—	0	—	ns
/CE Output Floating Time	t _{HZ}	—	10	—	10	ns
Address transition Time	t _{AX}	—	15	—	15	ns

(3) Page Mode Read/Write Cycle

Parameter	Symbol	Value (V _{DD} =1.8V to 2.5V)		Value (V _{DD} =2.5V to 3.6V)		Unit
		Min	Max	Min	Max	
Page Mode Write Cycle Time	t _{PWC}	25	—	25	—	ns
Page Mode Write Pulse Width	t _{WPP}	15	—	15	—	ns
Page Address Setup Time (/WE=L)	t _{ASP}	8	—	8	—	ns
Page Address Hold Time (/WE=L)	t _{AHP}	15	—	15	—	ns
Page Address Access Time	t _{AAP}	—	25	—	25	ns
Page Address Data Hold Time	t _{OHP}	3	—	3	—	ns
Page Mode Read Cycle Time	t _{PRCA}	25	—	25	—	ns
Page Mode Write Pre Charge Width	t _{WPHP}	7	—	7	—	ns

(4) Power ON/OFF Sequence and Sleep Mode Cycle

Parameter	Symbol	Value		Unit
		Min	Max	
/CE level hold time for Power ON	t _{PU}	450	—	μs
/CE level hold time for Power OFF	t _{PD}	85	—	ns
Power supply rising time	t _{VR}	50	—	μs/V
Power supply falling time	t _{VF}	100	—	μs/V
/ZZ active time	t _{ZZL}	1	—	μs
Sleep mode enable time	t _{ZZEN}	—	0	μs
/CE level hold time for Sleep mode release	t _{ZZEX}	450	—	μs

MS85R4M1TA

3. Pin Capacitance

Parameter	Symbol	Condition	Value			Unit
			Min	Typ	Max	
Input Capacitance	C_{IN}	$V_{DD} = 3.3\text{ V}$,	—	—	6	pF
Input/Output Capacitance (I/O pin)	$C_{I/O}$	$V_{IN} = V_{OUT} = 0\text{V} \sim V_{DD}$,	—	—	8	pF
/ZZ Pin Input Capacitance	C_{ZZ}	$f = 1\text{ MHz}$, $T_A = +25\text{ }^\circ\text{C}$	—	—	8	pF

■ AC Test Load Circuit

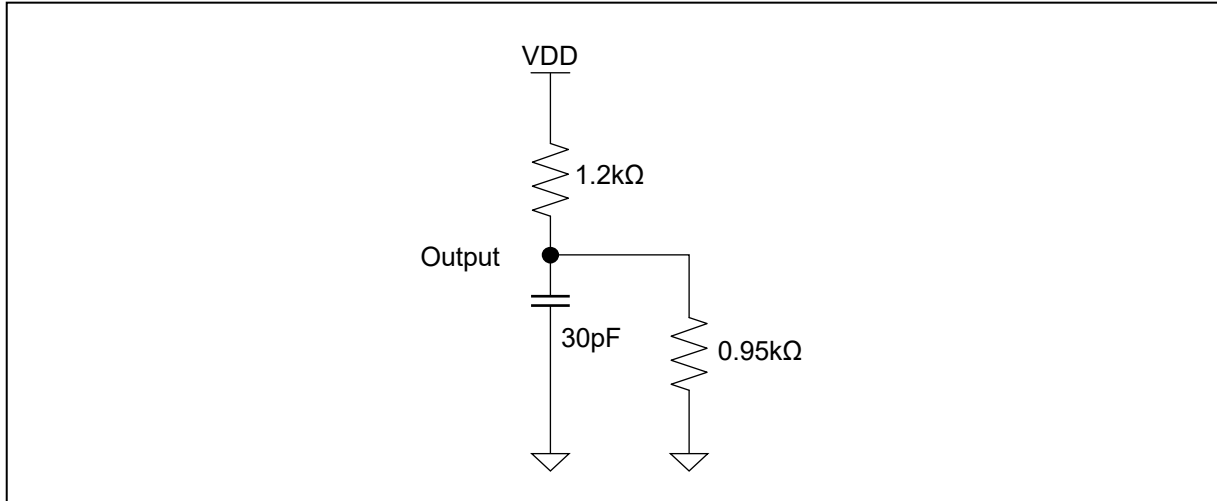

MS85R4M1TA

■ TIMING DIAGRAMS

1. Read Cycle Timing 1 (/CE, /OE Control)

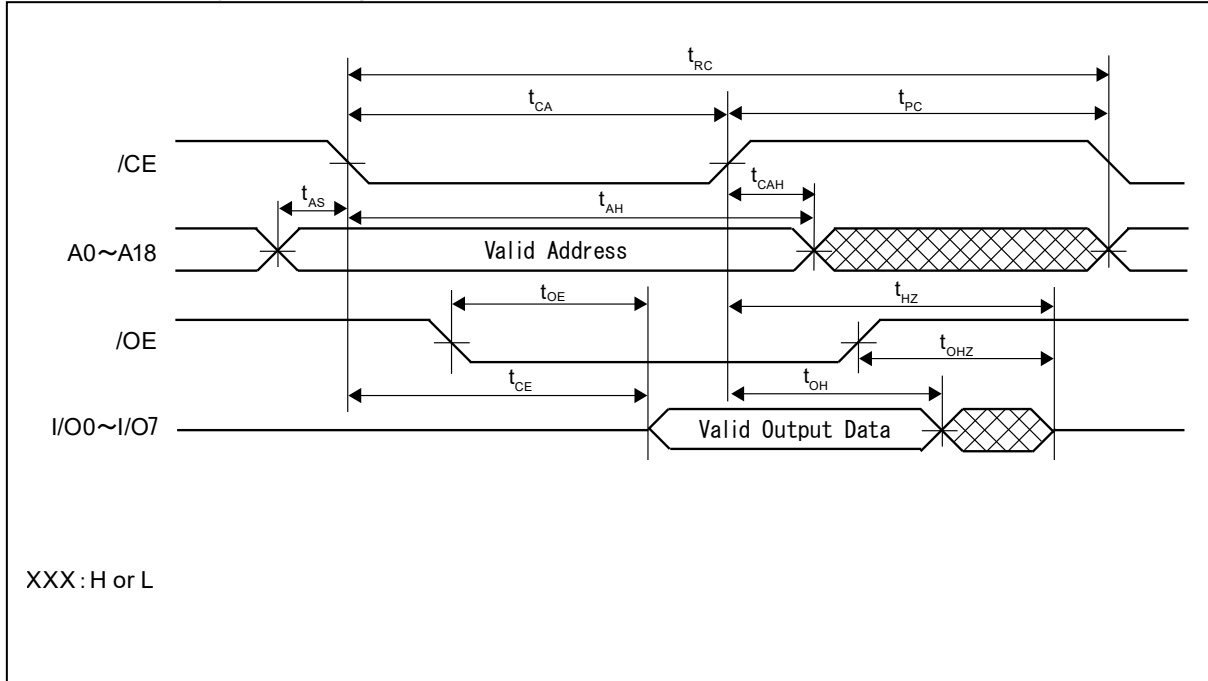

2. Read Cycle Timing 2 (Address Access)

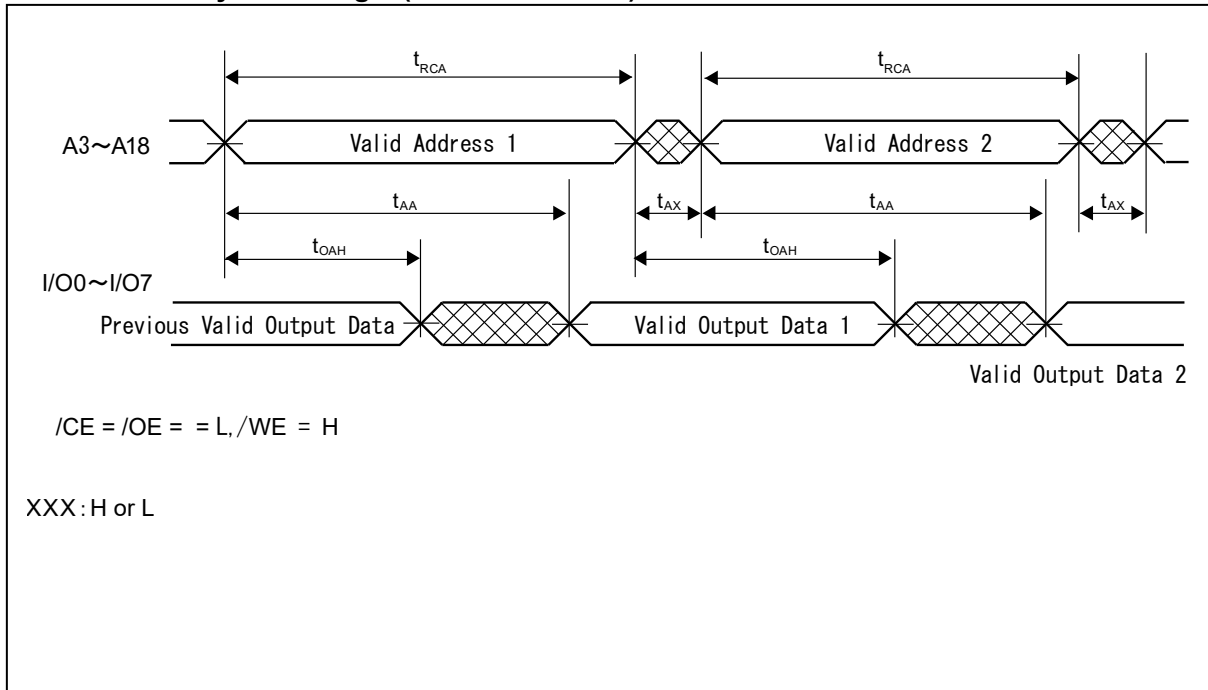

3. Read Cycle Timing 3 (Page Access)

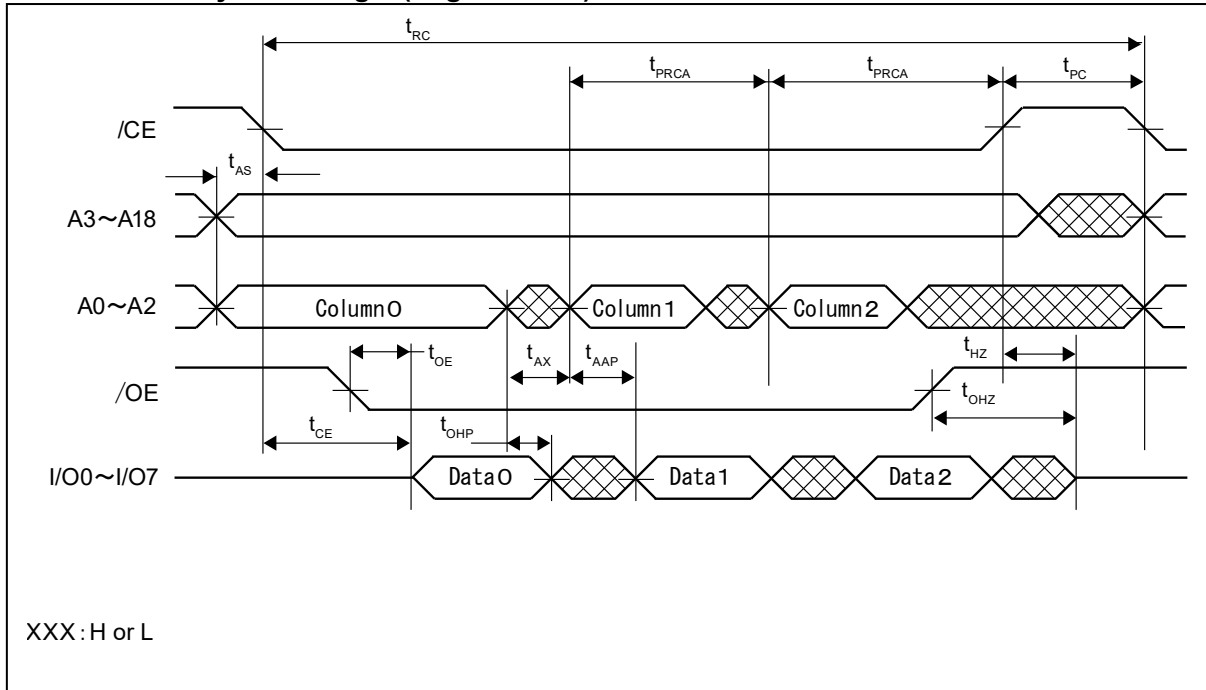

4. Write Cycle Timing 1 (/WE Control)

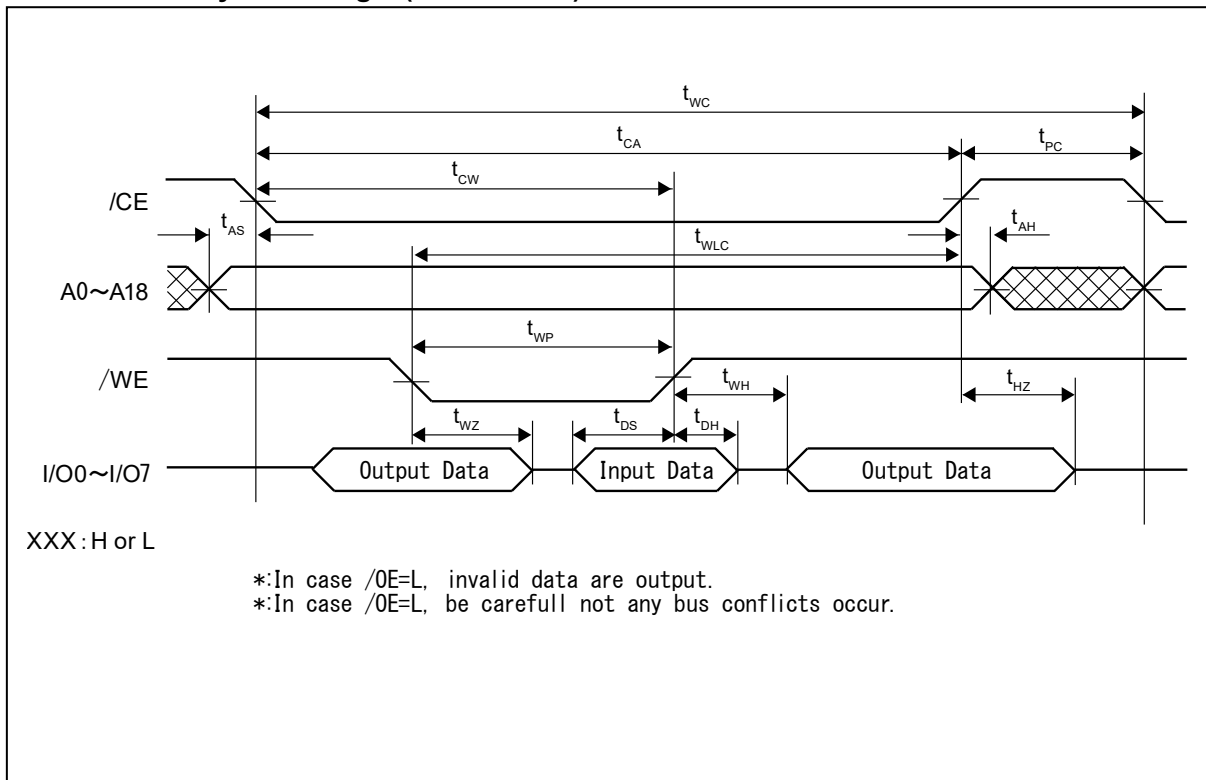

MS85R4M1TA

5. Write Cycle Timing 2 (/CE Control)

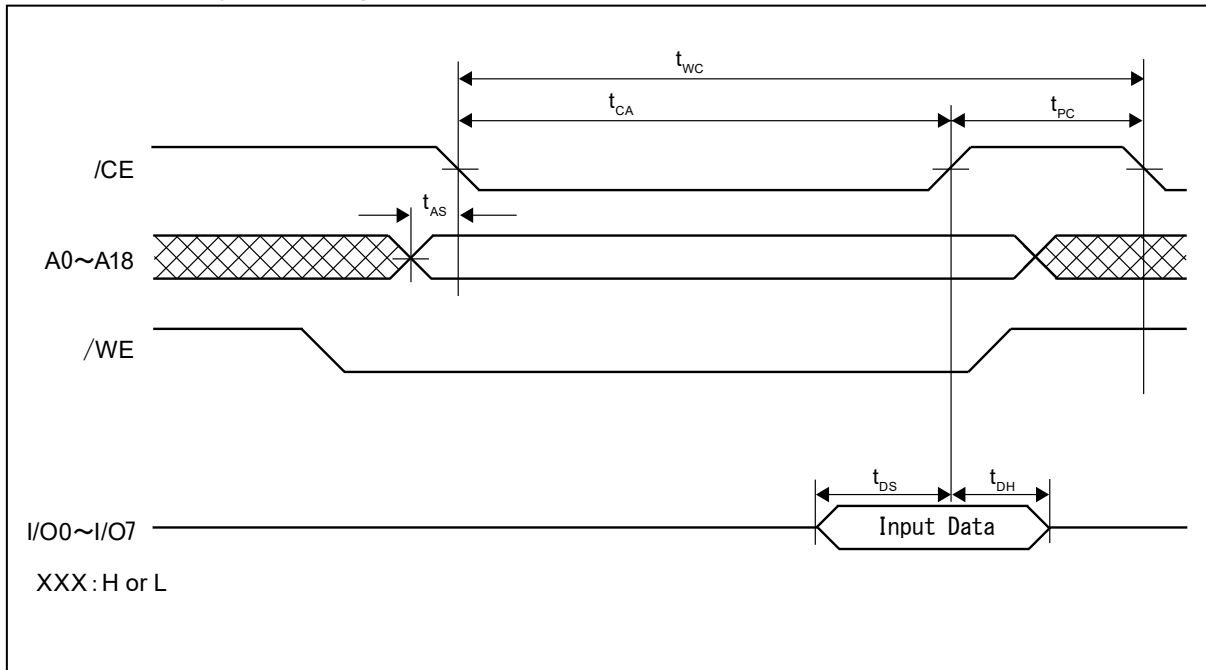

6. Write Cycle Timing 3 (Address Access and /WE Control)

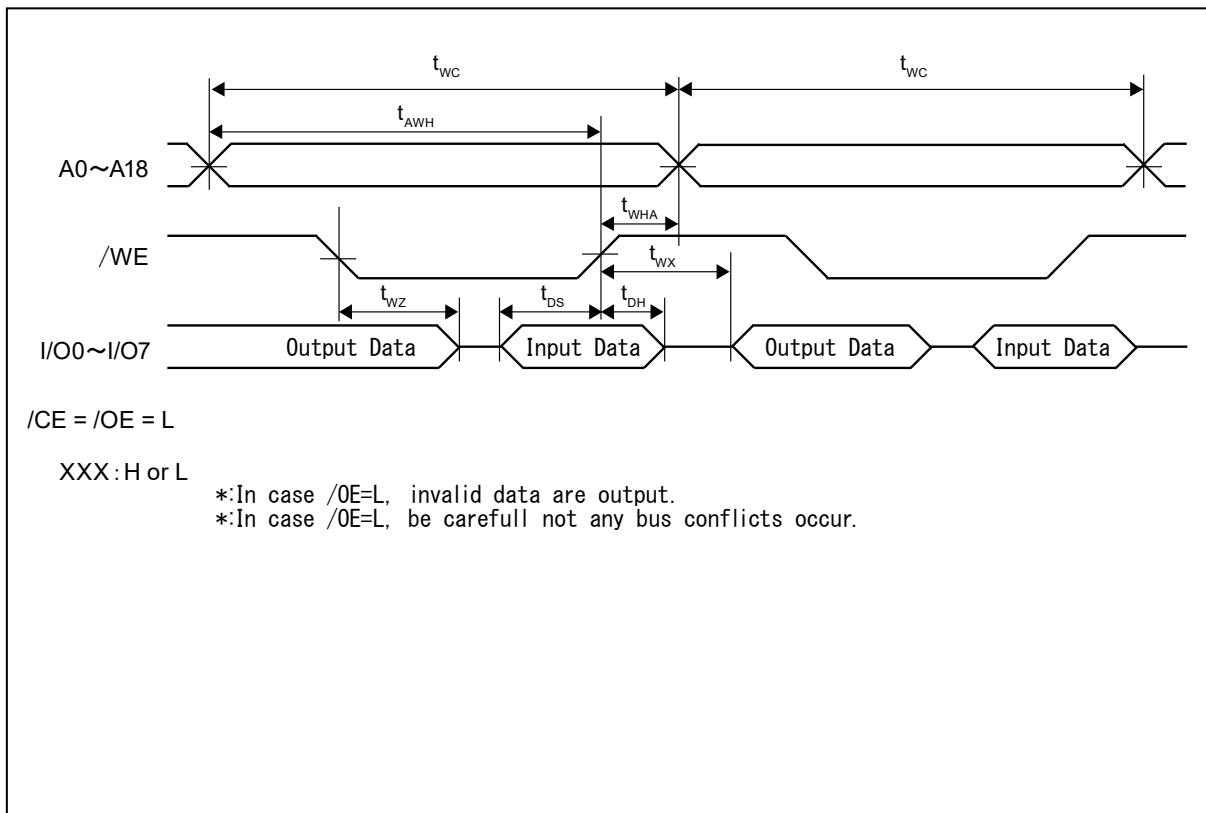

7. Write Cycle Timing 5 (Page Address Access)

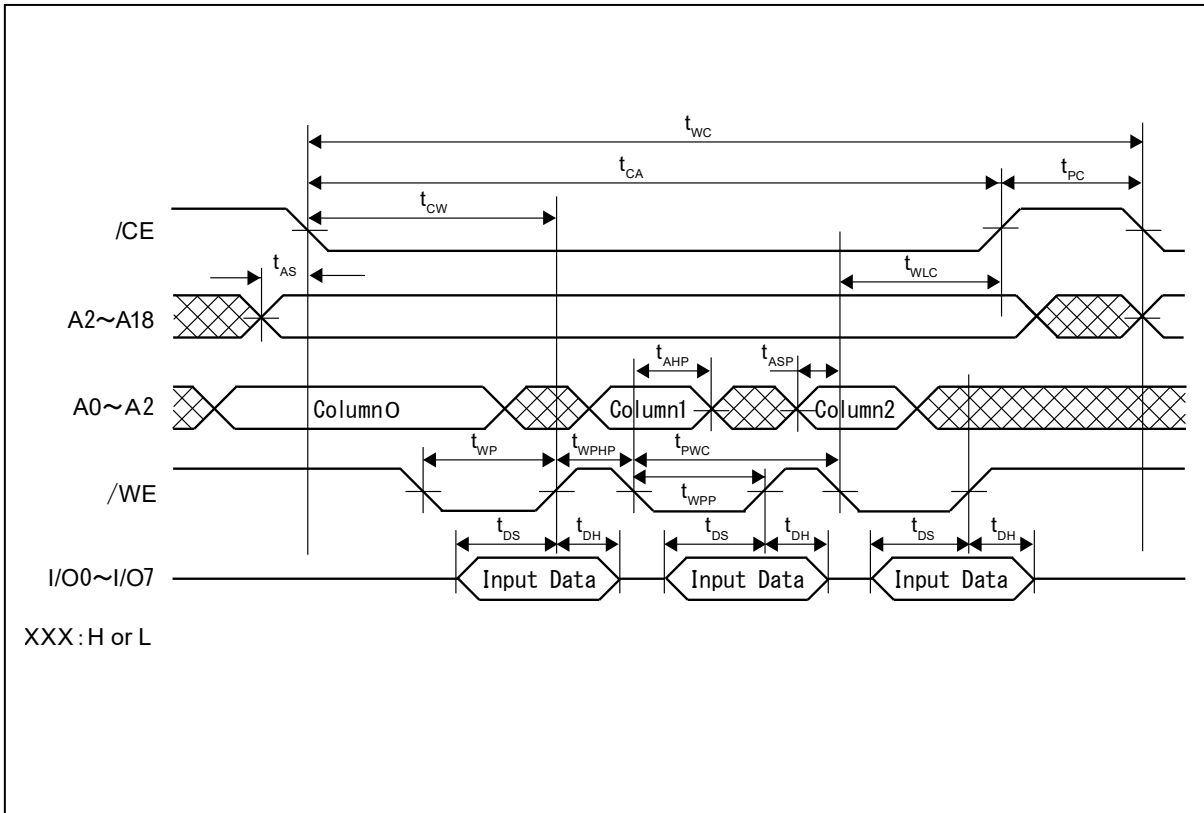

8. Sleep Mode Timing

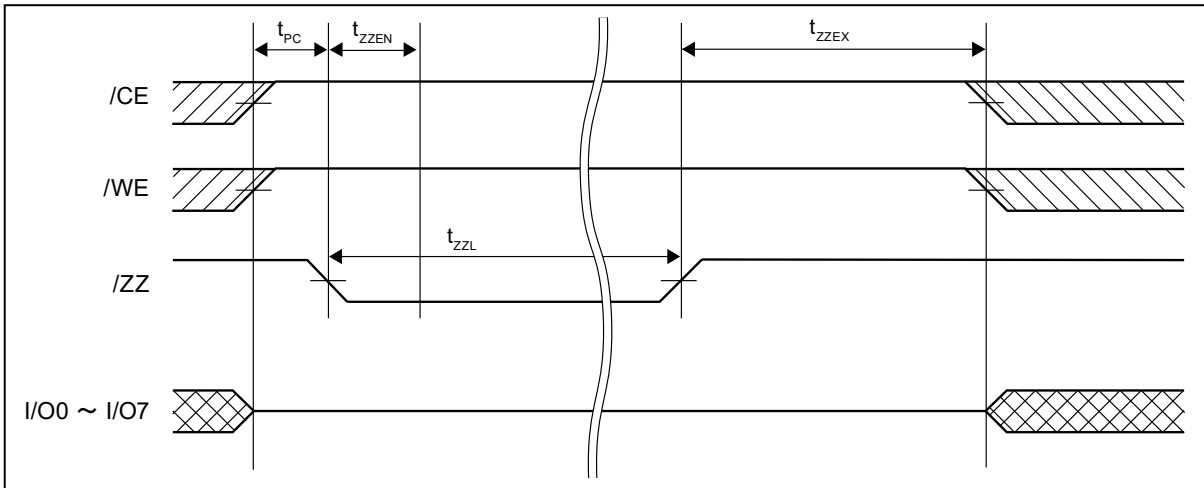

MS85R4M1TA

■ POWER ON/OFF SEQUENCE

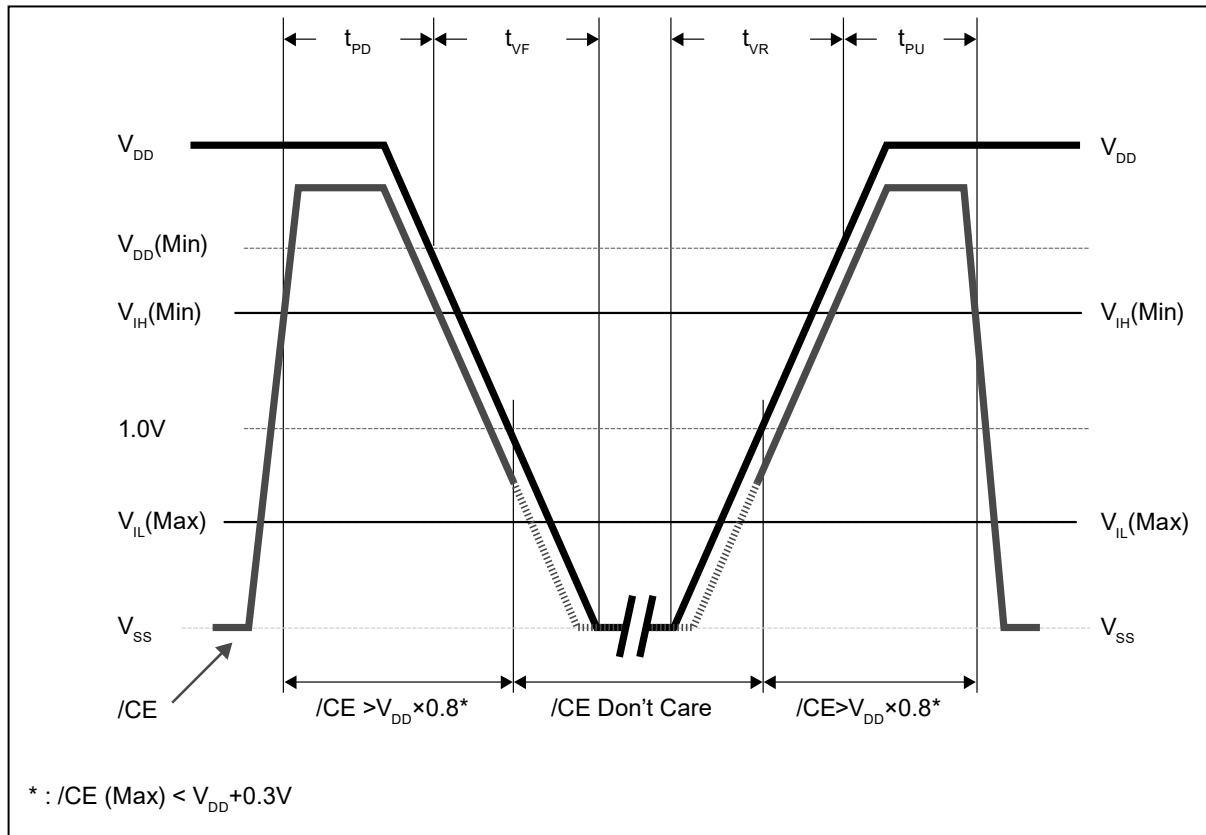

When applying relatively short term VDD pulse whose peak is more than 1.7V, it is required to set falling time, t_{VF} more than 0.4ms/V. (In case VDD rises over 1.7V and falls just after that, if this term is short, device may lose its function.)

■ FeRAM CHARACTERISTICS

Item	Min	Max	Unit	Parameter
Read/Write Endurance* ¹	10 ¹³ * ²	—	Times	Operation Ambient Temperature T _A = + 105 °C
	10 ¹⁴	—		Operation Ambient Temperature T _A = + 85 °C
Data Retention* ³	10	—	Years	Operation Ambient Temperature T _A = + 105 °C
	40	—		Operation Ambient Temperature T _A = + 85 °C
	95	—		Operation Ambient Temperature T _A = + 55 °C
	≥ 200	—		Operation Ambient Temperature T _A = + 35 °C

*1: The values for Read/Write Endurance apply to the total number of read and write operations per row in FeRAM. This is because FeRAM needs writing operation after each reading operations. When switching rows, the number of Read/Write operations is counted for each selected row. However, if only addresses A0, A1 and A2 are switched, no row switching occurs. The memory consists of 64 internal outputs per row, and switching only A0, A1 and A2 selects 8 of these outputs. Each row in the memory array has 64 internal outputs, and 8 outputs are selected by A0, A1 and A2. Therefore, once a certain address is selected, switching only A0, A1 and A2 does not change the selected row, and the Read/Write count is totaled as one operation. For other address switches, each corresponding row is counted once.

*2: Evaluating about minimum Read/Write Endurance at +105°C, over 10¹³ times.

*3: The minimum value of Date Retention refers to data retention term from first read/write after the device shipped. The value is estimated from qualification results.

■ NOTE ON USE

- We recommend programming of the device after reflow. Data written before reflow cannot be guaranteed.

MS85R4M1TA

■ ESD AND LATCH-UP

Test	DUT	Value
ESD HBM (Human Body Model) JESD22-A114 compliant	MS85R4M1TAFN-G-JAE2	$\geq 2000 \text{ V} $
ESD CDM (Charged Device Model) JESD22-C101 compliant		$\geq 1000 \text{ V} $
Latch-Up (C-V Method) Proprietary method		$\geq 200 \text{ V} $

■ REFLOW CONDITIONS AND FLOOR LIFE

[JEDEC MSL] : Moisture Sensitivity Level 3 (IPC/JEDEC J-STD-020E)

■ CURRENT STATUS ON CONTAINED RESTRICTED SUBSTANCES

This product complies with the regulations of REACH Regulations, EU RoHS Directive and China RoHS.

MS85R4M1TA

■ ORDERING INFORMATION

Part Number	Package	Shipping form	Minimum shipping quantity
MS85R4M1TAFN-G-JAE2	44-pin plastic TSOP	Tray	—*

*: Please contact our sales office about minimum shipping quantity.

MS85R4M1TA

■ PACKAGE DIMENSIONS

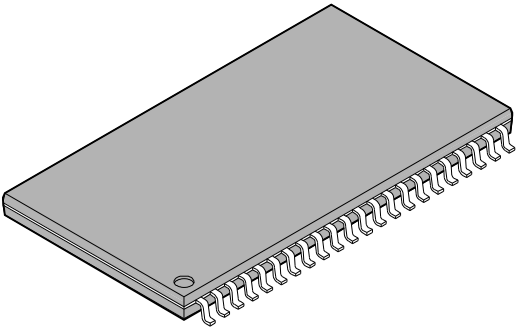
<p>44-pin plastic TSOP</p>  <p>MS85R4M1TAFN-G-JAE2</p>	Lead pitch	0.8mm	
	Package width × package length	10.16 × 18.41mm	
	Lead shape	Gullwing	
	Sealing method	Plastic mold	
	Mounting height	1.2mm (max.)	

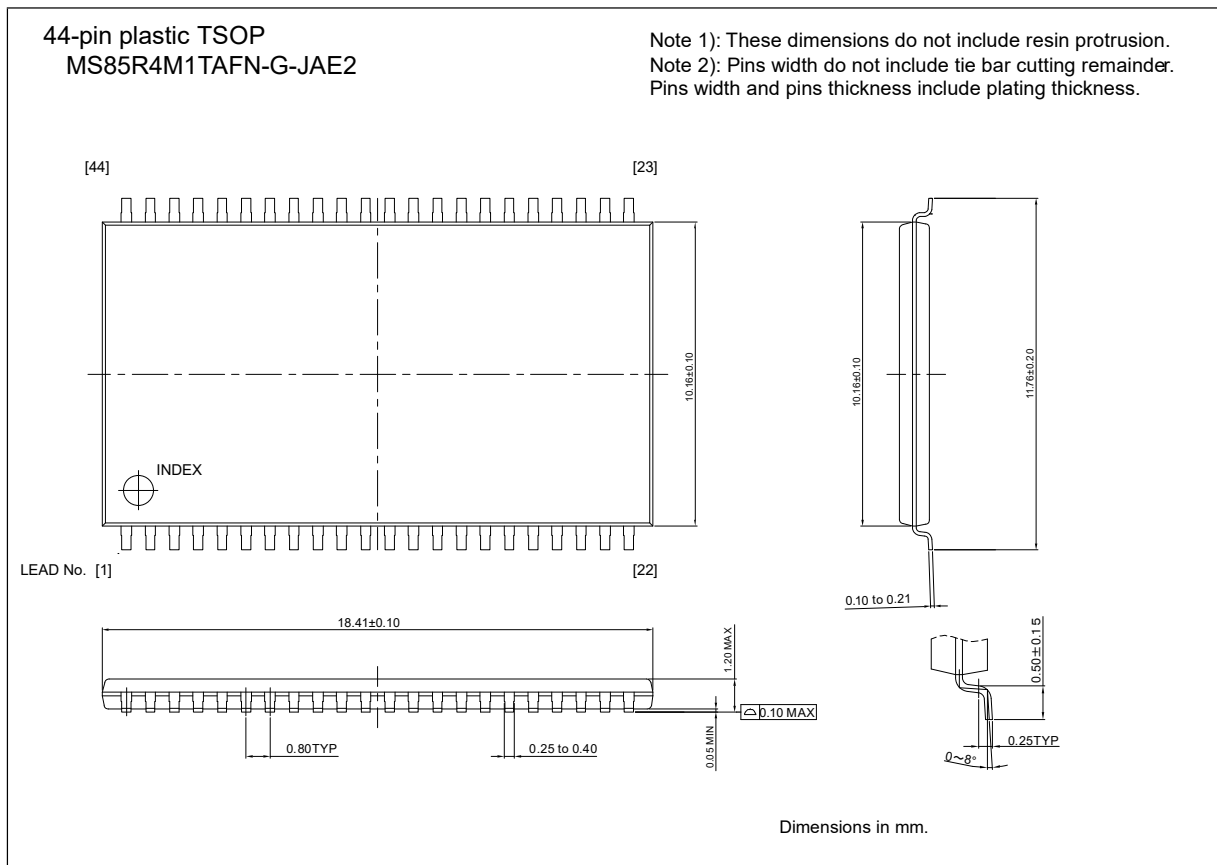

MS85R4M1TA

■ MARKING(Examples)

[MS85R4M1TAFN-G-JAE2]

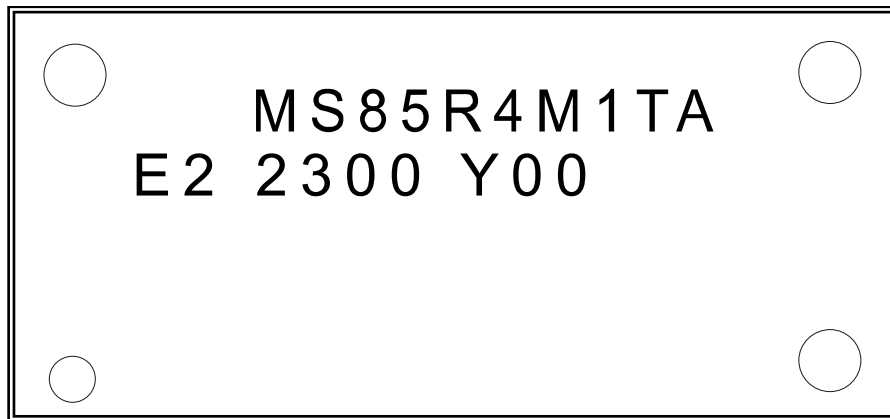

[44pin Plastic TSOP]

MS85R4M1TA: Product name

E2: (Lead free code)

2300 Y00:2300(Year and Week code)+Y00 (Trace code)

MS85R4M1TA

■ PACKING

MS85R4M1TAFN-G-JAE2

1.1 Tray dimensions

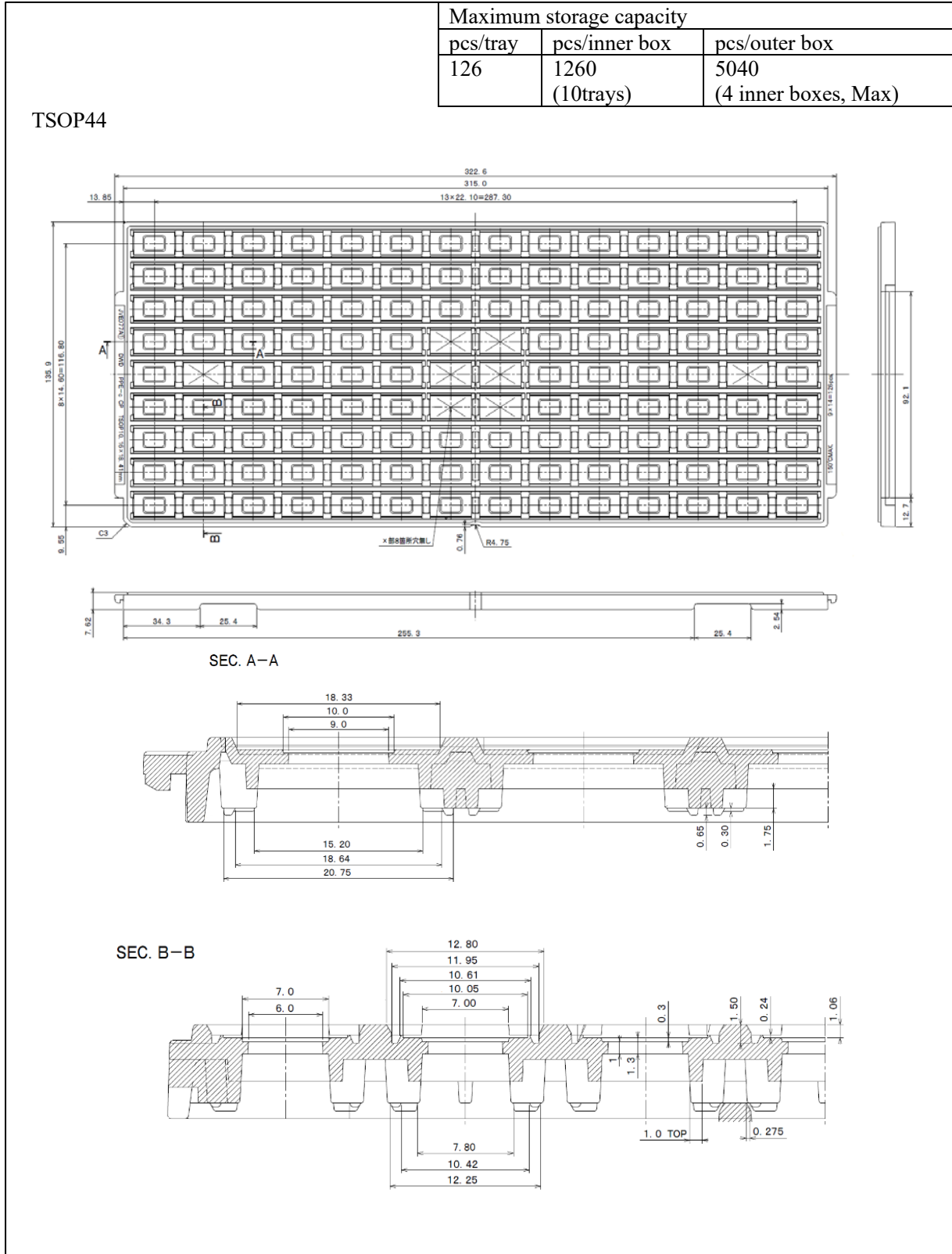

MS85R4M1TA

1.2 IC orientation

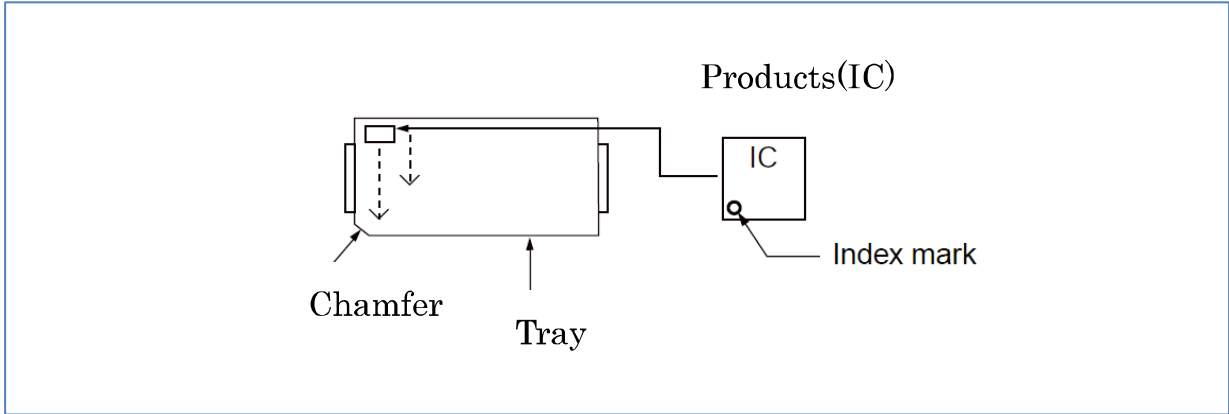

1.3 Product label indicators

Label I: Label on Inner box/Moisture Barrier Bag/ (It sticks it on the reel for the emboss taping)
 [C-3 Label (50mm x 100mm) Supplemental Label (20mm x 100mm)]

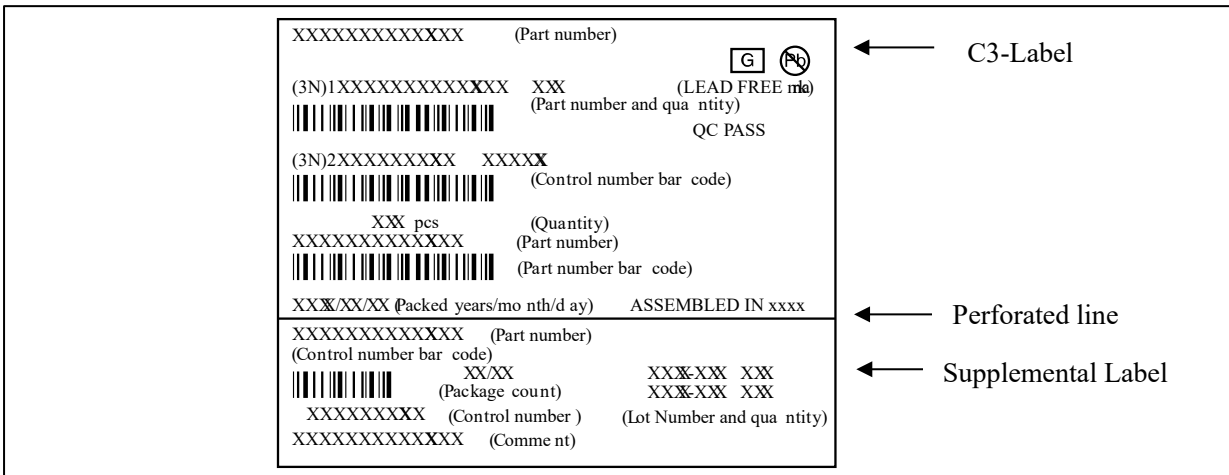

MS85R4M1TA

1.4 Dimensions for container

(1) Dimensions for inner box

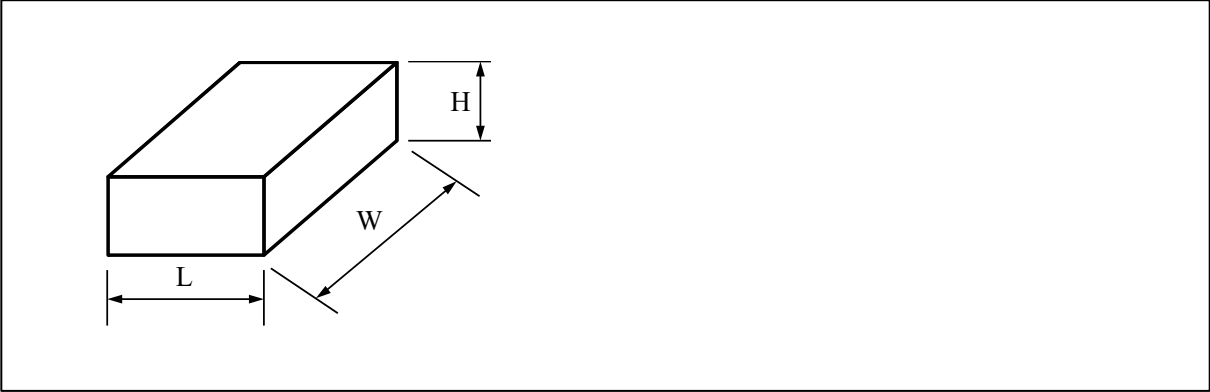

L	W	H
162	360	90

(Dimensions in mm)

(2) Dimensions for outer box

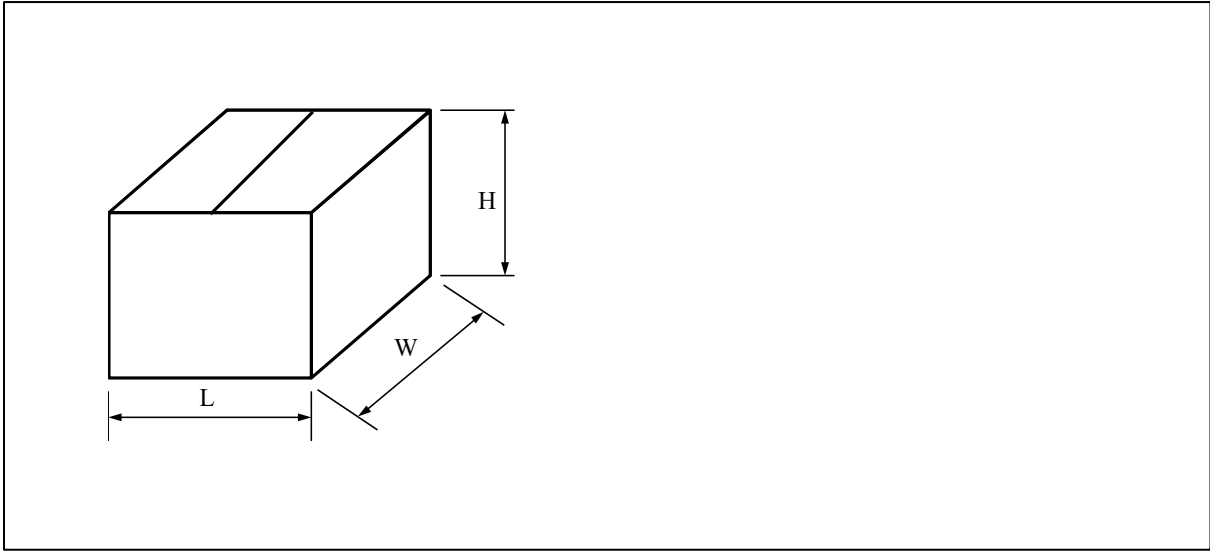

L	W	H
410	375	225

(Dimensions in mm)

■ MAJOR CHANGES IN THIS EDITION

A change on a page is indicated by a vertical line drawn on the left side of that page.

Page	Section	Change Results
P.1,16	Read/write endurance	10^{14} times/64bits → 10^{14} times(+85°C)